

REV.	DESCRIPTION	DATE
A	RELEASE	May 05, 2016

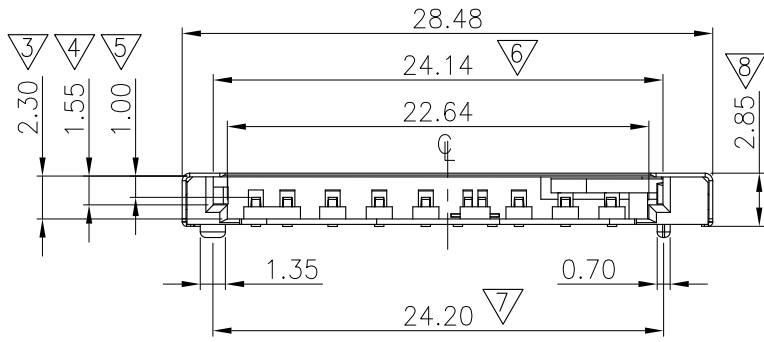
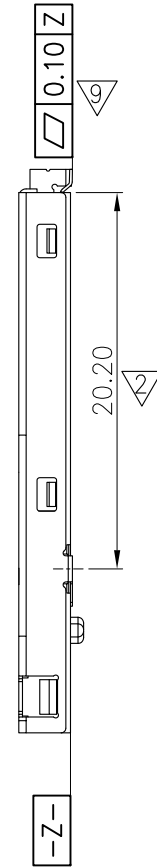
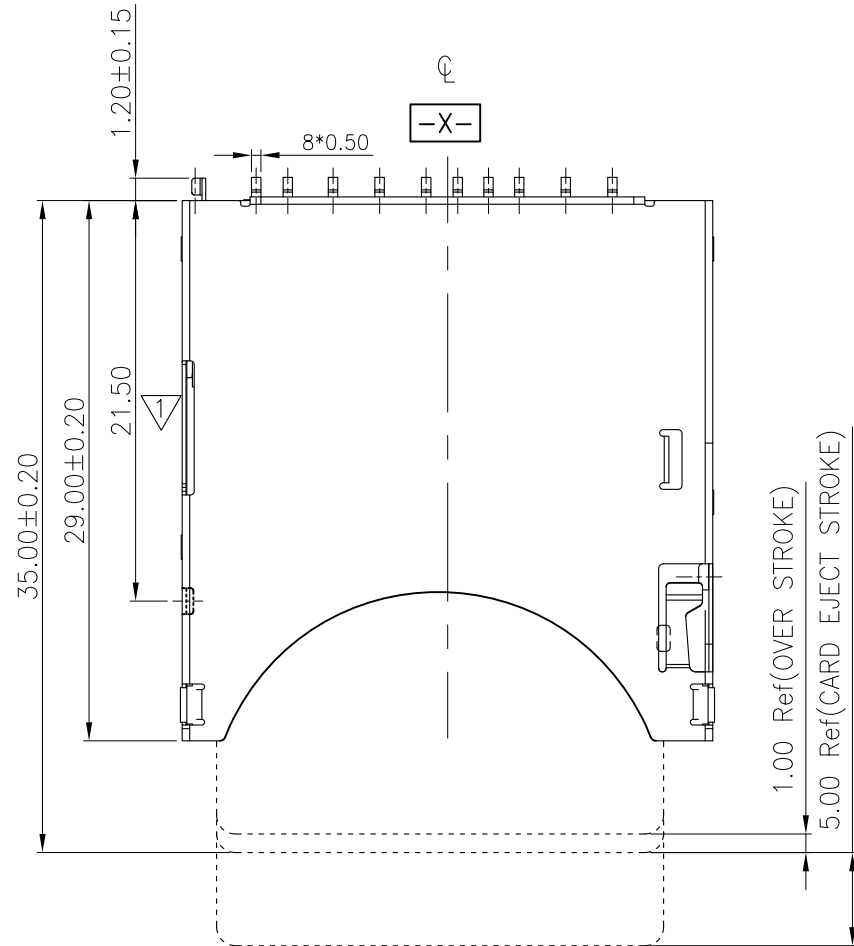

Specification

Material:
 Insulator: High Temperature Thermoplastic,UL 94V-0.
 Contact: Copper Alloy

Electrical:
 Current Rating: 0.5mA AC/DC max.
 Voltage Rating: 12V AC/DC.
 Ambient Temperature Range: -20°C~+60°C.
 Storage Temperature Range: -40°C~+70°C.
 Ambient Humidity Range: 95% R.H. Max.
 Contact Resistance: 100m max.
 Insulation Resistance: 1000M min./500VDC.
 Mating Cycles: 5,000 Insertions.

Usable Memory Card: SD&MMC Card.

PART NUMBER INFORMATION :

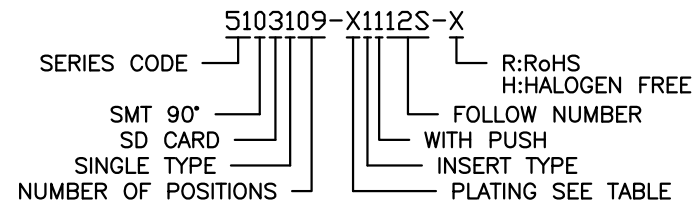

DESCRIPTION OF PLATING ON TERMINALS			
NO.	EXPLAIN	NO.	EXPLAIN
0	GOLD FLASH	3	GOLD 15u"
1	GOLD 5u"	4	GOLD 20u"
2	GOLD 10u"	H	G/F + TIN

TOLERANCE .0=±0.35 .00=±0.25 .000=±0.05 ANG.=±3°	DRAWER 221 CHECK 221 APP'D 221/221	INMO 东莞市英墨电子有限公司 INMO Electronics Co.,Ltd
	PRODUCT SPEC. —	
UNITS : mm	SCALE NONE	SIZE A5
SHEET 1 OF 1	REV. B	DRAW NO. R5103109-X112S-X

REV.	DESCRIPTION	DATE
A	RELEASE	May 05, 2016

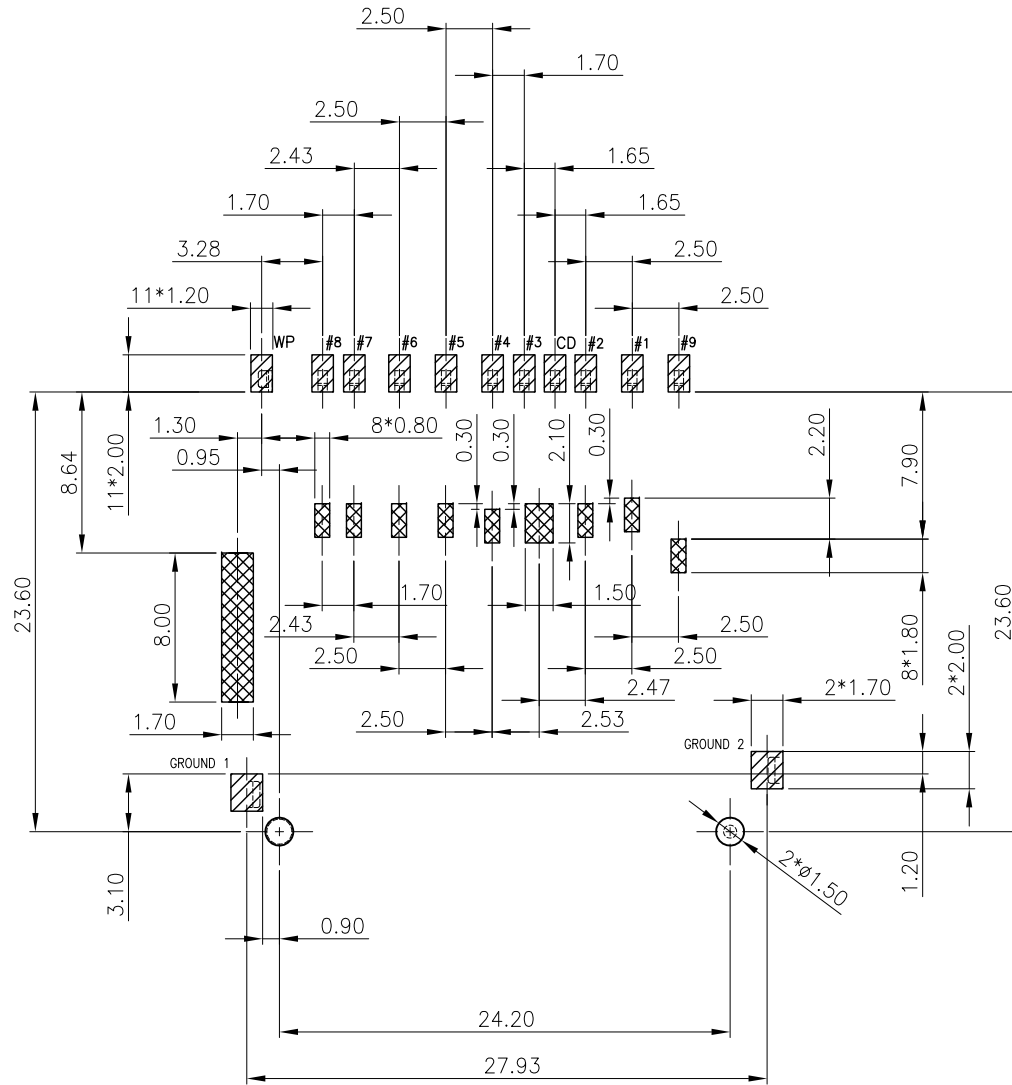

- PCB AREA
- CONNECT AREA
- KEEP OUT AREA

RECOMMEND PCB LAYOUT
TOLERANCE: ± 0.05
TOP VIEW

PIN NO.	PIN NAME
#1	(CD/DAT3)
#2	(CMD)
#3	(VSS1)
#4	(VDD)
#5	(CLK)
#6	(VSS2)
#7	(DAT0)
#8	(DAT1)
#9	(DAT2)

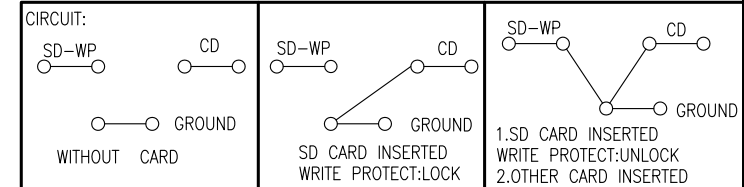

DESCRIPTION OF PLATING ON TERMINALS			
NO.	EXPLAIN	NO.	EXPLAIN
0	GOLD FLASH	3	GOLD 15u"
1	GOLD 5u"	4	GOLD 20u"
2	GOLD 10u"	H	G/F + TIN

TOLERANCE .0= ± 0.35 .00= ± 0.25 .000= ± 0.05 ANG.= $\pm 3^\circ$	DRAWER <i>221</i> CHECK <i>221</i> APP'D <i>221</i>	INMO 东莞市英墨电子有限公司 INMO Electronics Co.,Ltd
UNITS : mm	SCALE NONE SIZE A5 SHEET 1 OF 1 REV. B	NAME SD CARD 2.90H PUSH & LOCK
		DRAW NO. R5103109-X1112S-X

REV.	DESCRIPTION	DATE
A	RELEASE	May 05, 2016

THE PACKING FOR SD CARD SERIES PUSH TYPE

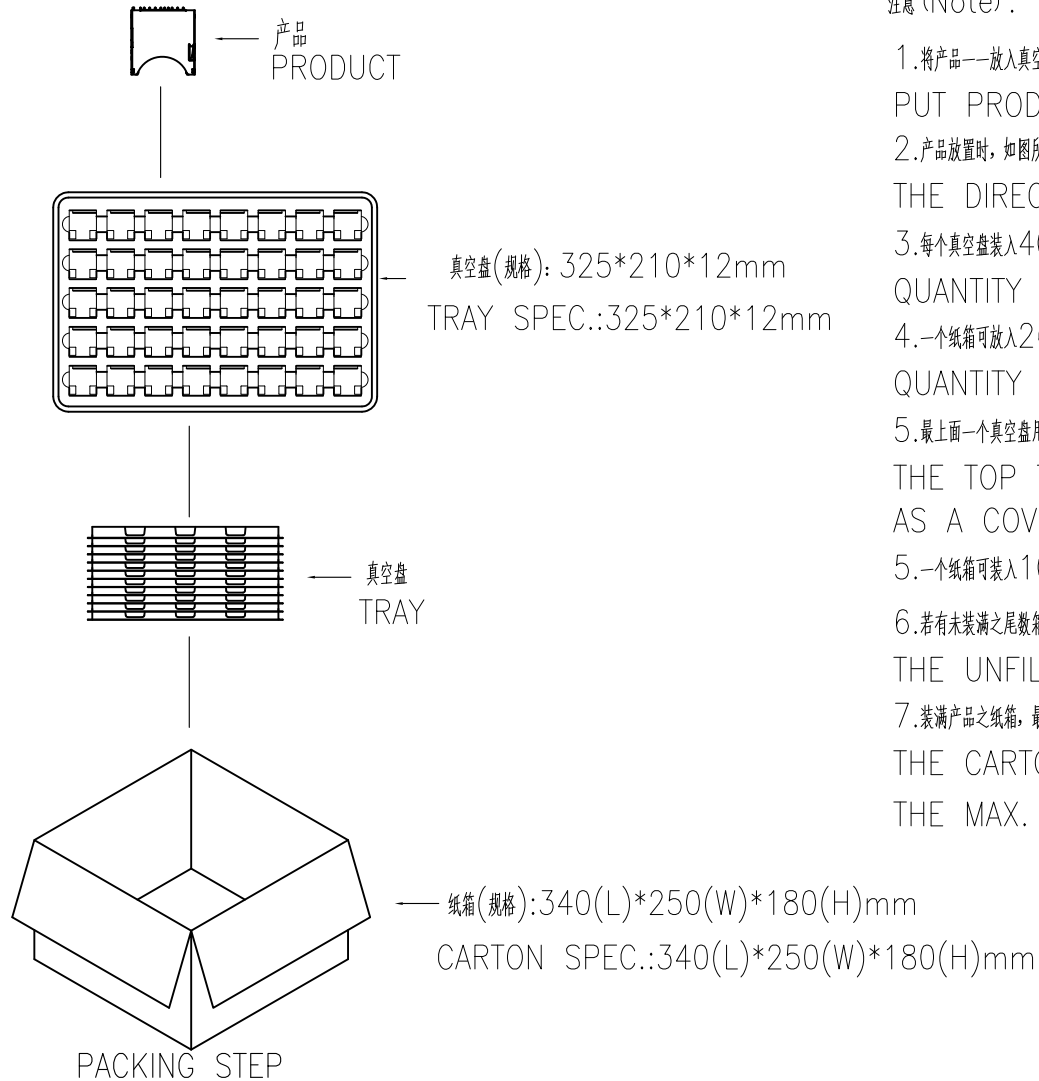

注意 (Note):

1. 将产品一一放入真空盒内, 依同一方向摆放
PUT PRODUCT INTO THE TRAY, AND AS SAME DIRECTION
2. 产品放置时, 如图所示
THE DIRECTION REFERS TO DRAWING
3. 每个真空盒装入40pcs 产品
QUANTITY OF PER TRAY: 40 PCS
4. 一个纸箱可放入26个真空盒
QUANTITY OF PER CARTON: 26 TRAYS
5. 最上面一个真空盒用作上盖, 不装入产品
THE TOP TRAY NOT PUT INTO PRODUCT AS A COVER TO PROTECT PRODUCT
5. 一个纸箱可装入1000 PCS产品
6. 若有未装满之尾数箱, 必须用缓冲材加满
THE UNFILLING-CARTON MUST BE FILLED WITH ASSUAGEMENT
7. 装满产品之纸箱, 最大堆积数量为5箱
THE CARTON FULLY FILLED WITH PRODUCTS
THE MAX. ACCUMULATING QUANTITY IS 5 CARTONS

TOLERANCE .0=±0.35 .00=±0.25 .000=±0.05 ANG.=±3°	DRAWER 221	INMO 东莞市英墨电子有限公司 INMO Electronics Co.,Ltd
	CHECK 221	
 UNITS : mm	APP'D 221	DRAW NO. R5103109-X1112S-X
	PRODUCT SPEC. —	SHEET 1 OF 1
SCALE NONE	SIZE A5	

REV.	DESCRIPTION	DATE
A	RELEASE	May 05, 2016

方向

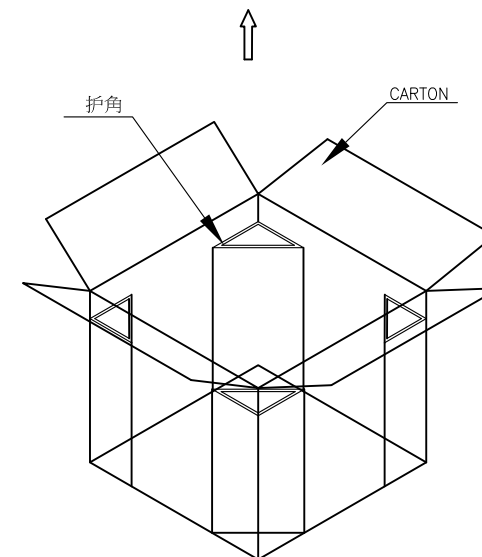
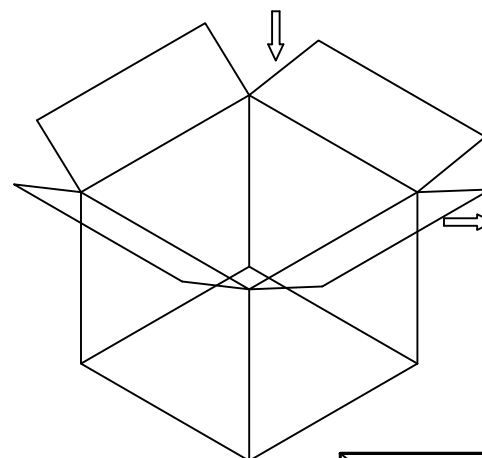
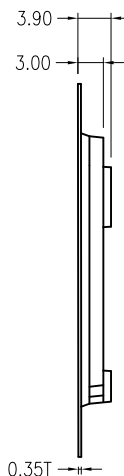
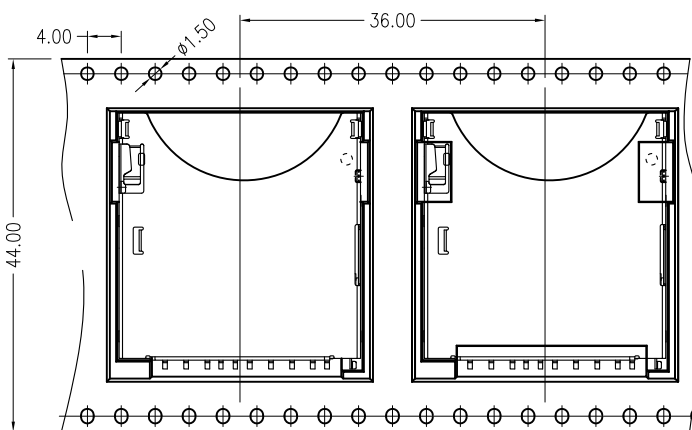
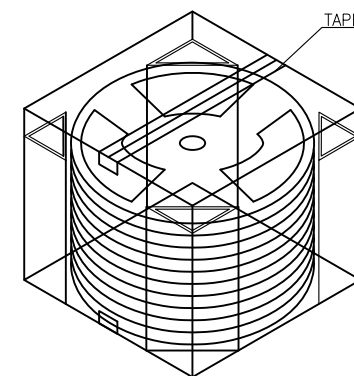
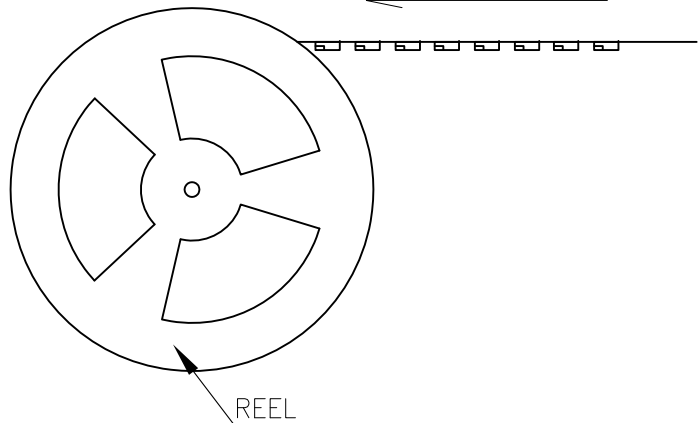

PACKING INFORMATION

PART NAME	
QUANTITY OF PER TRAY	400PCS/REEL
QUANTITY OF PER CARTON	6*400=2400PCS/CARTON
WEIGHT OF PER TRAY	
WEIGHT OF PER CARTON (NET WEIGHT)	
GROSS WEIGHT	
	350*350*345

TOLERANCE		DRAWER		INMO 东莞市英墨电子有限公司 INMO Electronics Co.,Ltd
.0=±0.35		321		
.00=±0.25		CHECK		NAME SD CARD 2.90H PUSH & LOCK
.000=±0.05		321		
ANG.=±3°		APP'D		DRAW NO. R5103109-X1112S-X
		321		
		PRODUCT SPEC.		
UNITS : mm				
SCALE	SIZE	SHEET	REV.	
NONE	A5	1 OF 1	B	